

FABRYKA MASZYN ELEKTRYCZNYCH S.A.

**indukta**

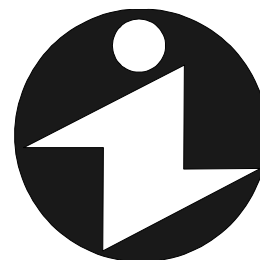

# KARTA KATALOGOWA CATALOGUE CARD

Trójfazowe silniki indukcyjne wielobiegowe  
z wirnikiem klatkowym do wentylatorów  
serii „W”

Three-phase induction multiple-speed motors  
with squirrel-cage rotor for fans  
„W” serie

**Cantoni**®  
**GROUP**

TELEFON: [48] [33] 827-20-00 ÷ 04  
FAX: [48] [33] 827-20-97 ÷ 99  
e-mail: [indukta@cantonigroup.com](mailto:indukta@cantonigroup.com)  
<http://www.indukta.com.pl>

**Charakterystyka wykonania:**

- moce znamionowe podane są dla pracy S1,
- napięcie znamionowe 380, 400 lub 500 [V],
- częstotliwość napięcia zasilania 50 lub 60 [Hz],
- temperatura otoczenia od -15 do +40[°C],
- wysokość instalowania do 1000 [m] n.p.m.,
- izolacja klasy F,
- stopień ochrony IP 55,
- z jednym czopem końcowym wału wg rysunku wymiarowego,
- standardowy układ połączenia silnika wg rysunku 1.

**Wykonania na życzenia:**

- z dwoma walcowymi czopami wału wg rysunku wymiarowego,
- z termistorowymi czujnikami temperatury w czołach uzwojenia,
- przystosowane do pracy w klimacie tropikalnym TH, TA lub MT (w wykonaniu TA lub MT ze względu na podwyższone temperatury otoczenia obowiązuje obniżka mocy znamionowej),
- fabryka wykonuje również silniki różniące się od wykonania podstawowego po uprzednim uzgodnieniu szczegółów konstrukcyjnych i terminów dostaw.

**Sposób zamawiania:**

- W zamówieniu należy podać pełne określenie typu silnika, moc, prędkość obrotową, napięcie zasilające, układ połączeń, częstotliwość, formę wykonania oraz inne szczegóły niekatalogowego lub specjalnego wykonania.

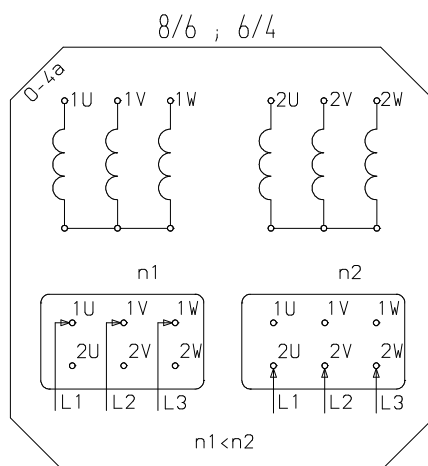
**Rys.1 Standardowe schematy połączeń zacisków****Features:**

- rated outputs for continuous duty,
- rated voltage 380, 400 or 500 [V],
- frequency 50 or 60 [Hz],
- environment temperature -15 to +40[°C],
- altitude up to 1000 [m] above sea level,
- insulation class F,
- protection degree IP 55,
- one free shaft extension according to dimension drawing,
- standard connexion diagram of the motor according to drawing 1.

**Features on request:**

- two cylindrical shaft extension according to dimension drawing,
- temperature – sensitive resistors in the winding ends,
- fit for work in tropical climate TH, TA or MT (for TA or MT rated output is decreased due to higher environment temperature),
- factory produces various types of motors but constructional details and delivery time are to be individual agreed

**How to order:**

- In the order there must be clearly given: full designation of the motor, rated output, rated speed, rated voltage, phase connection, frequency, mounting form and all other details for non catalogue execution.

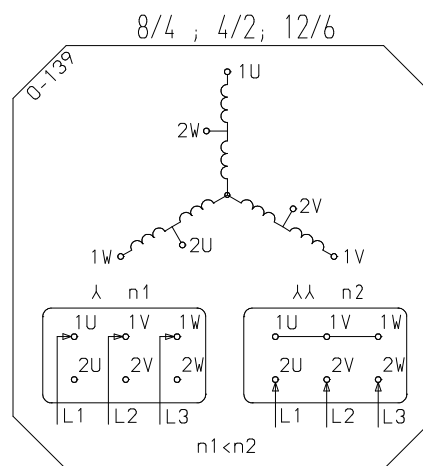
**Drawing 1 Standard diagrams of terminals connexion**

**PARAMETRY EKSPLOATACYJNE SILNIKÓW**  
**PERFORMANCES OF MOTORS**

Typ silnika Type of motor	Połączenie faz Phase connexion		$P_n$ Rated output		$n_n$ Rated speed	$\eta_n$ Efficiency	$\cos \varphi_n$ Power factor	$I_{In}$ przy nap. znam. Full-load amps at			$m_{rn}$ Locked rotor torque	$i_{rn}$ Locked rotor current	$m_{maxn}$ Break-down torque	$J$ Moment of inertia	Masa IM B3 Weight IM B3
	-		[kW]	[HP]	[min <sup>-1</sup> ]	[%]	-	[A]	[A]	[A]	[%]	[%]	[%]	[kgm <sup>2</sup> ]	[kg]
								380V	400V	500V					
<b>2p=4/2      <math>n_s=1500/3000</math> obr/min      jedno uzwojenie przelączalne</b> <b>rpm=1500/3000      one reconectional winding</b>															
Sh 90S-4/2W	4	Y	0,33	0,44	1420	64,6	0,86	0,9	0,9	0,7	150	390	210	0,0023	14,0
	2	YY	1,40	1,90	2725	66,2	0,93	3,5	3,3	2,7	160	385	210		
Sh 90L-4/2W	4	Y	0,50	0,68	1420	73,2	0,85	1,22	1,2	0,9	185	450	290	0,0026	16,5
	2	YY	2,00	2,70	2775	73,9	0,91	4,55	4,3	3,5	180	470	250		
Sg 100L-4/2AW	4	Y	0,70	0,94	1400	72,8	0,89	1,6	1,5	1,2	135	375	235	0,0070	23,1
	2	YY	2,60	3,50	2810	76,9	0,92	5,6	5,3	4,3	180	470	240		
Sg 100L-4/2BW	4	Y	0,85	1,14	1380	73,4	0,90	2,0	1,9	1,5	135	405	180	0,0082	24,3
	2	YY	3,30	4,50	2795	76,8	0,91	7,1	6,7	5,4	185	510	225		
Sg 112M-4/2W	4	Y	1,20	1,60	1445	79,6	0,87	2,6	2,5	2,0	185	630	290	0,0119	32,8
	2	YY	4,80	6,60	2860	78,4	0,84	11,1	10,5	8,4	230	615	275		
Sg 132S-4/2W	4	Y	1,30	1,80	1470	83,8	0,82	2,9	2,8	2,2	180	700	300	0,0270	57,0
	2	YY	5,20	7,10	2910	77,0	0,87	11,8	11,2	9,0	220	670	290		
Sg 132S-4/2WB	4	Y	1,50	2,00	1450	75,7	0,87	3,5	3,3	2,7	535	150	365	0,0210	47,0
	2	YY	5,90	8,00	2895	76,7	0,87	13,4	12,7	10,2	175	610	300		
Sg 132M-4/2W	4	Y	1,80	2,40	1470	85,0	0,82	3,9	3,7	3,0	220	750	340	0,0350	65,0
	2	YY	7,10	9,50	2930	79,7	0,88	15,4	14,6	11,7	230	790	310		
Sg 132M-4/2WB	4	Y	2,00	2,70	1460	84,9	0,87	4,1	3,9	3,1	170	620	230	0,0350	69,0
	2	YY	8,00	10,70	2900	81,3	0,91	16,4	15,6	12,5	190	700	230		
Sg 160M-4/2W	4	Y	2,70	3,60	1470	85,5	0,80	6,0	5,7	4,6	190	700	320	0,0620	105,0
	2	YY	11,00	15,00	2920	84,4	0,90	22,0	20,9	16,7	200	740	290		
Sg 160L-4/2W	4	Y	4,00	5,50	1470	87,3	0,84	8,3	7,9	6,3	190	690	300	0,0760	122,0
	2	YY	15,00	20,00	2930	86,6	0,90	29,2	27,7	22,2	210	830	300		
Sg 180M-4/2W	4	Y	5,00	6,80	1475	86,8	0,83	10,5	10,0	8,0	220	660	300	0,1330	155,0
	2	YY	19,50	26,40	2930	85,5	0,92	37,7	35,8	28,7	170	650	250		
Sg 180L-4/2W	4	Y	6,00	8,10	1480	87,9	0,82	12,6	12,0	9,6	250	770	330	0,1730	175,0
	2	YY	24,00	32,50	2940	87,0	0,91	46,0	43,7	35,0	220	750	300		
<b>2p=6/4      <math>n_s=1000/1500</math> obr/min      dwa uzwojenia nieprzelączalne</b> <b>rpm=1000/1500      two unreconnectional windings</b>															
Sh 90S-6/4W	6	Y	0,28	0,37	950	62,9	0,720	0,9	0,9	0,7	215	400	235	0,0025	13,8
	4	Y	0,80	1,07	1410	66,9	0,850	2,2	2,1	1,7	135	400	185		
Sh 90L-6/4W	6	Y	0,37	0,50	945	59,2	0,770	1,2	1,1	0,9	160	345	280	0,0032	16,7
	4	Y	1,10	1,50	1410	67,7	0,830	3,0	2,9	2,3	135	415	245		
Sg 100L-6/4AW	6	Y	0,60	0,81	950	58,1	0,760	2,1	2,0	1,6	130	340	210	0,0088	23,8
	4	Y	1,70	2,30	1410	71,6	0,830	4,4	4,2	3,3	140	425	220		
Sg 100L-6/4BW	6	Y	0,75	1,00	960	64,9	0,75	2,4	2,2	1,8	170	440	240	0,0094	25,5
	4	Y	2,2	3,00	1415	73,0	0,83	5,5	5,2	4,2	170	460	220		
Sg 112M-6/4W	6	Y	0,90	1,21	975	73,0	0,690	2,7	2,6	2,1	210	545	300	0,0178	33,3
	4	Y	3,00	4,00	1420	78,4	0,840	6,9	6,6	5,2	165	525	235		
Sg 132S-6/4W	6	Y	1,20	1,60	940	69,3	0,860	3,0	2,9	2,3	120	380	200	0,0310	56,0
	4	Y	3,40	4,60	1450	80,0	0,870	7,4	7,0	5,6	160	580	230		
Sg 132M-6/4W	6	Y	1,70	2,30	950	75,5	0,860	4,0	3,8	3,0	130	470	205	0,0390	67,0
	4	Y	4,50	6,20	1450	82,7	0,880	9,4	8,9	7,1	170	600	230		
Sg 160M-6/4W	6	Y	2,50	3,40	930	75,1	0,860	5,9	5,6	4,5	100	330	150	0,0690	95,0
	4	Y	6,70	9,00	1450	82,2	0,860	14,4	13,7	10,9	160	650	250		
Sg 160L-6/4W	6	Y	3,30	4,50	950	79,2	0,860	7,3	6,9	5,5	130	430	210	0,0970	125,0
	4	Y	10,00	13,60	1455	85,0	0,850	21,0	19,9	16,0	240	790	310		
Sg 180L-6/4W	6	Y	6,20	8,40	970	82,0	0,880	13,0	12,4	9,9	170	480	180	0,1900	165,0
	4	Y	13,00	17,50	1470	85,4	0,890	26,0	24,7	19,8	220	650	230		

Typ silnika Type of motor	Połączenie faz	$P_n$		$n_n$	$\eta_n$	$\cos \varphi_n$	$I_{1n}$ przy nap. znam.			$m_{rn}$	$i_{rn}$	$m_{maxn}$	$J$	Masa IM B3	
	Phase connexion	Rated output		Rated speed	Efficiency	Power factor	Full-load amps at			Locked rotor torque	Locked rotor current	Break-down torque	Moment of inertia	Weight IM B3	
	-	[kW]	[HP]	[min <sup>-1</sup> ]	[%]	-	[A]	[A]	[A]	[%]	[%]	[%]	[kgm <sup>2</sup> ]	[kg]	
								380V	400V	500V					
		2p=8/4 ns=750/1500 obr/min rpm=750/1500				jedno uzwojenie przełączalne one reconnectional winding									
Sh 90S-8/4W	8	Y	0,23	0,31	700	55,0	0,66	1,0	0,9	0,8	160	280	220	0,0025	14,7
	4	YY	1,00	1,36	1405	69,6	0,81	2,7	2,6	2,1	155	420	210		
Sh 90L-8/4W	8	Y	0,33	0,44	685	61,2	0,68	1,2	1,1	0,9	165	285	210	0,0028	16,8
	4	YY	1,30	1,80	1400	73,0	0,81	3,3	3,1	2,5	195	465	270		
Sg 100L-8/4W	8	Y	0,44	0,60	680	63,8	0,74	1,4	1,3	1,1	125	270	190	0,0094	25,7
	4	YY	1,80	2,40	1400	75,2	0,88	4,1	3,9	3,1	150	450	195		
Sg 100L-8/4AW	8	Y	0,50	0,68	690	62,5	0,72	1,7	1,6	1,3	140	305	230	0,0088	22,1
	4	YY	2,00	2,70	1400	72,7	0,84	5,0	4,8	3,8	160	440	230		
Sg 100L-8/4BW	8	Y	0,65	0,88	685	64,4	0,73	2,1	2,0	1,6	135	285	185	0,0094	23,6
	4	YY	2,60	3,50	1405	72,5	0,87	6,3	6,0	4,8	150	455	200		
Sg 112M-8/4W	8	Y	0,75	1,00	700	71,8	0,75	2,1	2,0	1,6	145	330	190	0,0178	32,7
	4	YY	3,00	4,00	1415	78,9	0,86	6,7	6,4	5,1	155	535	220		
Sg 112M-8/4WB	8	Y	0,90	1,21	700	70,9	0,74	2,6	2,5	2,0	160	375	220	0,018	39,3
	4	YY	3,60	4,90	1420	78,5	0,85	8,2	7,8	6,2	170	580	250		
Sg 132S-8/4W	8	Y	1,00	1,36	700	72,3	0,75	2,8	2,7	2,1	130	360	200	0,031	56,0
	4	YY	4,00	5,50	1420	80,4	0,90	8,4	8,0	6,4	160	530	200		
Sg 132S-8/4WB	8	Y	1,10	1,50	705	70,3	0,74	3,2	3,1	2,4	135	410	200	0,031	57,0
	4	YY	4,50	6,20	1415	78,1	0,88	9,9	9,5	7,6	170	620	230		
Sg 132M-8/4W	8	Y	1,40	1,90	700	74,6	0,75	3,8	3,6	2,9	130	360	190	0,04	66,0
	4	YY	5,30	7,20	1420	82,8	0,90	10,8	10,3	8,2	170	600	230		
Sg 132M-8/4WB	8	Y	1,40	1,90	720	79,5	0,68	3,9	3,7	3,0	170	490	240	0,034	68,5
	4	YY	6,10	8,30	1435	83,5	0,88	12,6	12,0	9,6	220	720	300		
Sg 160M-8/4W	8	Y	2,00	2,70	710	81,4	0,75	5,0	4,8	3,8	110	380	190	0,067	95,0
	4	YY	7,80	10,40	1420	83,8	0,90	15,7	14,9	11,9	160	580	230		
Sg 160L-8/4W	8	Y	3,00	4,00	710	82,6	0,74	7,5	7,1	5,7	130	420	210	0,097	125,0
	4	YY	11,50	15,60	1440	86,0	0,90	22,6	21,5	17,2	190	710	280		
Sg 180L-8/4W	8	Y	3,90	5,40	730	86,0	0,77	8,9	8,5	6,8	170	420	180	0,22	165,0
	4	YY	15,80	21,10	1460	86,0	0,90	31,1	29,5	23,6	200	610	210		

Typ silnika Type of motor	Połączenie faz	$P_n$		$n_n$	$\eta_n$	$\cos \varphi_n$	$I_{1n}$ przy nap. znam.			$m_{rn}$	$i_{rn}$	$m_{maxn}$	$J$	Masa IM B3	
	Phase connexion	Rated output		Rated speed	Efficiency	Power factor	Full-load amps at			Locked rotor torque	Locked rotor current	Break-down torque	Moment of inertia	Weight IM B3	
	-	[kW]	[HP]	$[\text{min}^{-1}]$	[%]	-	[A]	[A]	[A]	[%]	[%]	[%]	$[\text{kgm}^2]$	[kg]	
<b>2p=8/6 ns=750/1000 obr/min rpm=750/1000 dwa uzwojenie nieprzełączalne two unreconnectional winding</b>															
Sh 90S-8/6W	8	Y	0,24	0,32	705	46,30	0,640	1,2	1,1	0,9	165	260	215	0,0025	14,8
	6	Y	0,48	0,65	930	62,60	0,750	1,6	1,5	1,2	140	325	210		
Sh 90L-8/6W	8	Y	0,33	0,44	700	48,30	0,670	1,5	1,4	1,1	180	275	210	0,0028	16,5
	6	Y	0,66	0,89	920	64,80	0,790	2,0	1,9	1,5	140	320	190		
Sg 100L-8/6AW	8	Y	0,45	0,61	710	56,60	0,670	1,8	1,7	1,4	135	320	275	0,0088	21,9
	6	Y	0,90	1,21	940	67,60	0,800	2,5	2,4	1,9	115	360	280		
Sg 100L-8/6BW	8	Y	0,60	0,81	715	49,80	0,670	2,7	2,6	2,1	145	300	235	0,0094	23,3
	6	Y	1,25	1,70	945	63,10	0,780	3,9	3,7	3,0	145	370	220		
Sg 112M-8/6W	8	Y	1,00	1,36	720	67,80	0,640	3,5	3,3	2,7	205	425	275	0,0178	32,9
	6	Y	1,80	2,40	955	75,10	0,770	4,7	4,5	3,6	160	455	185		
Sg 132S-8/6W	8	Y	0,90	1,21	725	69,00	0,650	3,1	2,9	2,3	115	330	260	0,0220	57,0
	6	Y	2,20	3,00	960	79,89	0,754	5,6	5,3	4,2	120	415	240		
Sg 132M-8/6AW	8	Y	1,50	2,00	715	69,4	0,69	4,8	4,5	3,6	150	420	240	0,0318	57,5
	6	Y	3,30	4,40	955	81,5	0,75	8,2	7,8	6,2	200	590	280		
Sg 132M-8/6BW	8	Y	1,70	2,30	705	71,3	0,71	5,1	4,8	3,9	190	430	250	0,0040	72,0
	6	Y	4,00	5,50	935	80,3	0,79	9,6	9,1	7,3	250	560	280		
<b>2p=12/6 ns=500/1000 obr/min rpm=500/1000 jedno uzwojenie przełączalne one reconnectional winding</b>															
Sg 112M-12/6W	12	Y	0,30	0,40	480	58,6	0,44	1,8	1,7	1,3	190	300	270	0,018	32,0
	6	Y	1,60	2,10	970	77,5	0,66	4,8	4,5	3,6	290	640	300		
Sg 160M-12/6W	12	Y	1,00	1,36	465	70,2	0,59	3,7	3,5	2,8	80	260	140	0,007	105,0
	6	Y	5,50	7,48	945	79,9	0,85	12,3	11,7	9,4	130	510	220		

Producent zastrzega sobie prawo zmian parametrów zawartych w katalogu wynikających z ciągłego doskonalenia produktów bez wcześniejszego informowania.

As part of our development program, we reserve the rights to alert or amend any of the specifications without giving prior notice.

### Wymiary montażowe silników na łapach Mounting dimensions for foot-mounted motors

Typ Type	A	B	C	D,DA	E,EA	F,FA	GA,GC	H	K
	[mm]								
Sh 90S ...	140	100	56	24j6	50	8h9	27,0	90	10
Sh 90L ...	140	125	56	24j6	50	8h9	27,0	90	10
Sg 100L ...	160	140	63	28j6	60	8h9	31,0	100	12
Sg 112M ...	190	140	70	28j6	60	8h9	31,0	112	12
Sg 132S ...	216	140	89	38k6	80	10h9	41,0	132	12
Sg 132M ...	216	178	89	38k6	80	10h9	41,0	132	12
Sg 160M ...	254	210	108	42k6	110	12h9	45,0	160	15
Sg 160L ...	254	254	108	42k6	110	12h9	45,0	160	15
Sg 180M ...	279	241	121	48k6	110	14h9	51,5	180	15
Sg 180L ...	279	279	121	48k6	110	14h9	51,5	180	15

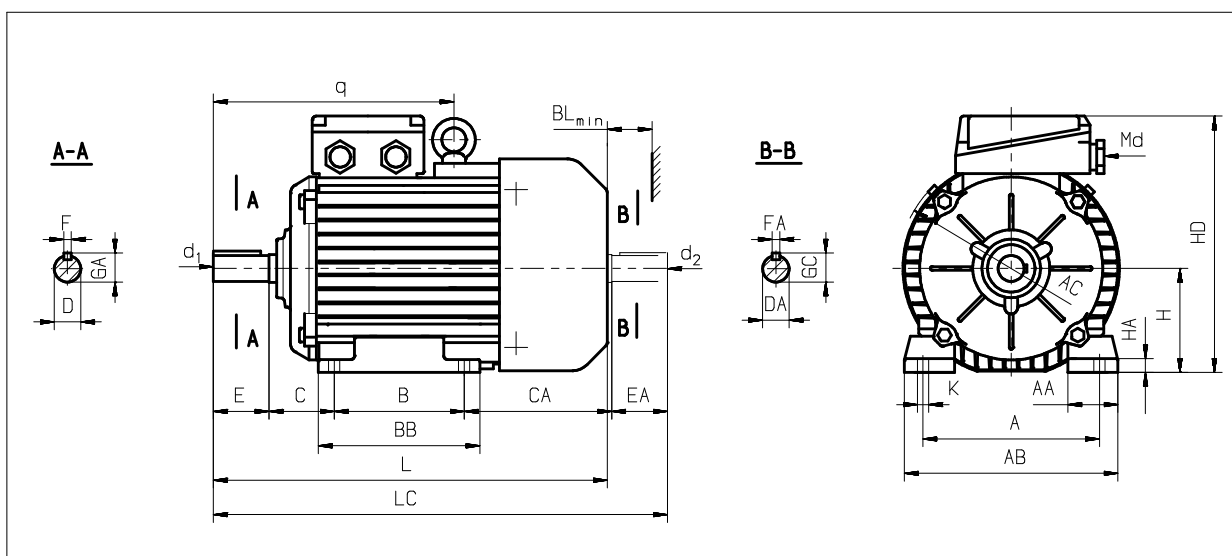

### Wymiary gabarytowe silników na łapach Overall dimensions for foot-mounted motors

Typ Type	AA	AB	AC	BB	BL	CA	d1,d2	HA	HD	L	LC	q	Md	Łożysko nr Bearing No
	[mm]													
Sh 90S ...	50	170	185	153	15	104	M8	10	220	305	360	-	M 20 x 1,5	6205 2Z
Sh 90L ...	50	170	185	153	15	104	M8	10	220	330	385	-	M 20 x 1,5	6205 2Z
Sg 100L ...	45	200	206	172	20	116	M10	14	240	376	441	-	M 20 x 1,5	6206 2Z
Sg 112M ...	54	230	245	174	20	119	M10	14	276	384	449	257	M 25 x 1,5	6306 2Z
Sg 112M-8/4WB	54	230	245	174	20	146	M10	14	276	411	476	257	M 25 x 1,5	6306 2Z
Sg 132S ...	56	278	274	182	40	160	M12	16	310	463	549	284	M 25 x 1,5	6308 2Z
Sg 132M ...	56	278	274	220	40	160	M12	16	310	501	587	284	M 25 x 1,5	6308 2Z
Sg 160M ...	60	305	323	256	40	200	M16	20	370	612	738	350	M 40 x 1,5	6309 2Z
Sg 160L ...	60	305	323	300	40	200	M16	20	370	656	782	350	M 40 x 1,5	6309 2Z
Sg 180M ...	70	350	360	320	40	243	M16	26	408	705	825	358	M 40 x 1,5	6311 2Z
Sg 180L ...	70	350	360	320	40	205	M16	26	408	705	825	358	M 40 x 1,5	6311 2Z

Wymiar AB dla silników wielkości 132 z łapami odlewanymi wraz z korpusem wynosi 260 mm.

As to motors of size „132” the dimension AB amounts to 260 mm in case the feet are together with frame casted.

#### Formy wykonania:

- IM 1001, IM 1011, IM 1031, IM 1051, IM 1061, IM 1071 - wg IEC 34-7, PN-EN 60034-7
- IM B3, IM B6, IM B7, IM B8, IM V5, IM V6 - wg IEC 34-7, PN-EN 60034-7

#### Mounting forms:

- IM 1001, IM 1011, IM 1031, IM 1051, IM 1061, IM 1071 - per IEC 34-7, PN-EN 60034-7
- IM B3, IM B6, IM B7, IM B8, IM V5, IM V6 - per IEC 34-7, PN-EN 60034-7

### Wymiary montażowe silników kołnierzowych Mounting dimensions for flange-mounted motors

Typ Type	D,DA	E,EA	F,FA	GA,GC	M	N	P	S	T
	[mm]								
SKh 90S ...	24j6	50	8h9	27,0	165	130j6	200	12	3,5
SKh 90L ...	24j6	50	8h9	27,0	165	130j6	200	12	3,5
SKg 100L ...	28j6	60	8h9	31,0	215	180j6	250	15	4
SKg 112M ...	28j6	60	8h9	31,0	215	180j6	250	15	4
SKg 132S ...	38k6	80	10h9	41,0	265	230j6	300	15	4
SKg 132M ...	38k6	80	10h9	41,0	265	230j6	300	15	4
SKg 160M ...	42k6	110	12h9	45,0	300	250j6	350	19	5
SKg 160L ...	42k6	110	12h9	45,0	300	250j6	350	19	5
SKg 180M ...	48k6	110	14h9	51,5	300	250j6	350	19	5
SKg 180L ...	48k6	110	14h9	51,5	300	250j6	350	19	5
SKg 180L ...	48k6	110	14h9	51,5	300	250j6	350	19	5

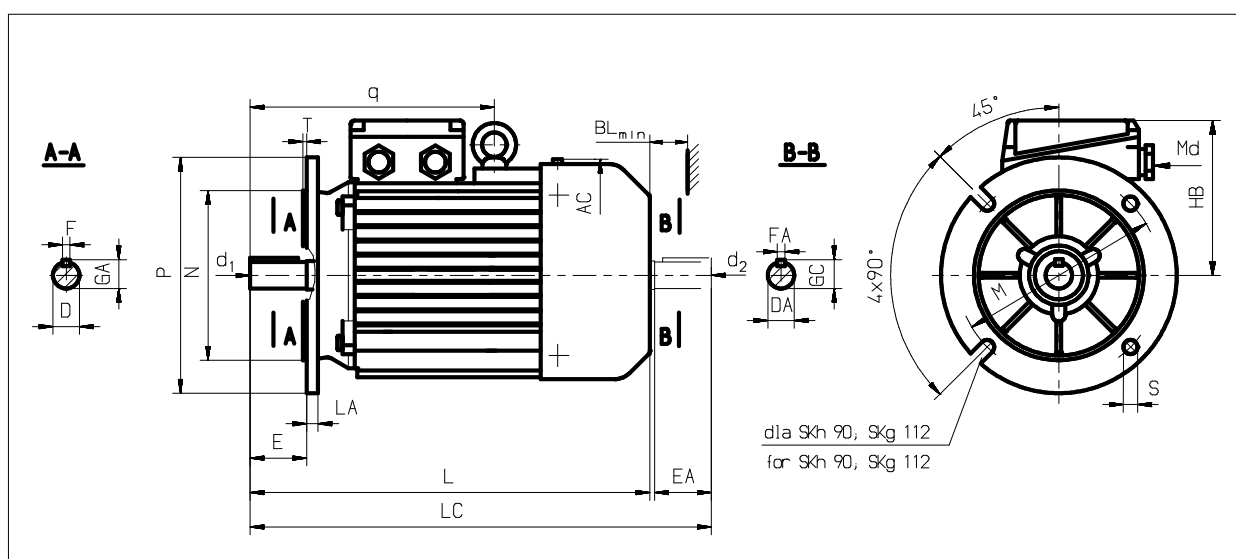

### Wymiary gabarytowe silników kołnierzowych Overall dimensions for flange-mounted motors

Typ Type	AC	BL	d1,d1	HB	L	LA	LC	q	Md	Łożyisko nr Bearing No
	[mm]									
SKh 90S ...	185	15	M8	130	305	8	360	-	M 20 x 1,5	6205 2Z
SKh 90L ...	185	15	M8	130	330	8	385	-	M 20 x 1,5	6205 2Z
SKg 100L ...	206	20	M10	140	376	11	441	-	M 20 x 1,5	6206 2Z
SKg 112M ...	245	20	M10	164	384	12	449	257	M 25 x 1,5	6306 2Z
SKg 112M-8/4WB	245	20	M10	164	411	12	476	257	M 25 x 1,5	6306 2Z
SKg 132S ...	274	40	M12	178	463	12	549	284	M 25 x 1,5	6308 2Z
SKg 132M ...	274	40	M12	178	501	12	587	284	M 25 x 1,5	6308 2Z
SKg 160M ...	323	40	M16	210	612	13	738	350	M 40 x 1,5	6309 2Z
SKg 160L ...	323	40	M16	210	656	13	782	350	M 40 x 1,5	6309 2Z
SKg 180M ...	360	40	M16	228	705	13	825	358	M 40 x 1,5	6311 2Z
SKg 180L ...	360	40	M16	228	705	13	825	358	M 40 x 1,5	6311 2Z

#### Formy wykonania:

- IM 3001, IM 3011, IM 3031 - wg IEC 34-7, PN-EN 60034-7
- IM B5, IM V1, IM V3 - wg IEC 34-7, PN-EN 60034-7

#### Mounting forms:

- IM 3001, IM 3011, IM 3031 - per IEC 34-7, PN-EN 60034-7
- IM B5, IM V1, IM V3 - per IEC 34-7, PN-EN 60034-7

### Wymiary montażowe silników kołnierzowych na łapach

### Mounting dimensions for foot-flange-mounted motors

Typ Type	A	B	C	D,DA	E,EA	F,FA	GA,GC	H	K	M	N	P	S	T
	[mm]													
SLh 90S ...	140	100	56	24j6	50	8h9	27,0	90	10	165	130j6	200	12	3,5
SLh 90L ...	140	125	56	24j6	50	8h9	27,0	90	10	165	130j6	200	12	3,5
SLg 100L ...	160	140	63	28j6	60	8h9	31,0	100	12	215	180j6	250	15	4,0
SLg 112M ...	190	140	70	28j6	60	8h9	31,0	112	12	215	180j6	250	15	4,0
SLg 132S ...	216	140	89	38k6	80	10h9	41,0	132	12	265	230j6	300	15	4,0
SLg 132M ...	216	178	89	38k6	80	10h9	41,0	132	12	265	230j6	300	15	4,0
SLg 160M ...	254	210	108	42k6	110	12h9	45,0	160	15	300	250j6	350	19	5,0
SLg 160L ...	254	254	108	42k6	110	12h9	45,0	160	15	300	250j6	350	19	5,0
SLg 180M ...	279	241	121	48k6	110	14h9	51,5	180	15	300	250j6	350	19	5,0
SLg 180L ...	279	279	121	48k6	110	14h9	51,5	180	15	300	250j6	350	19	5,0

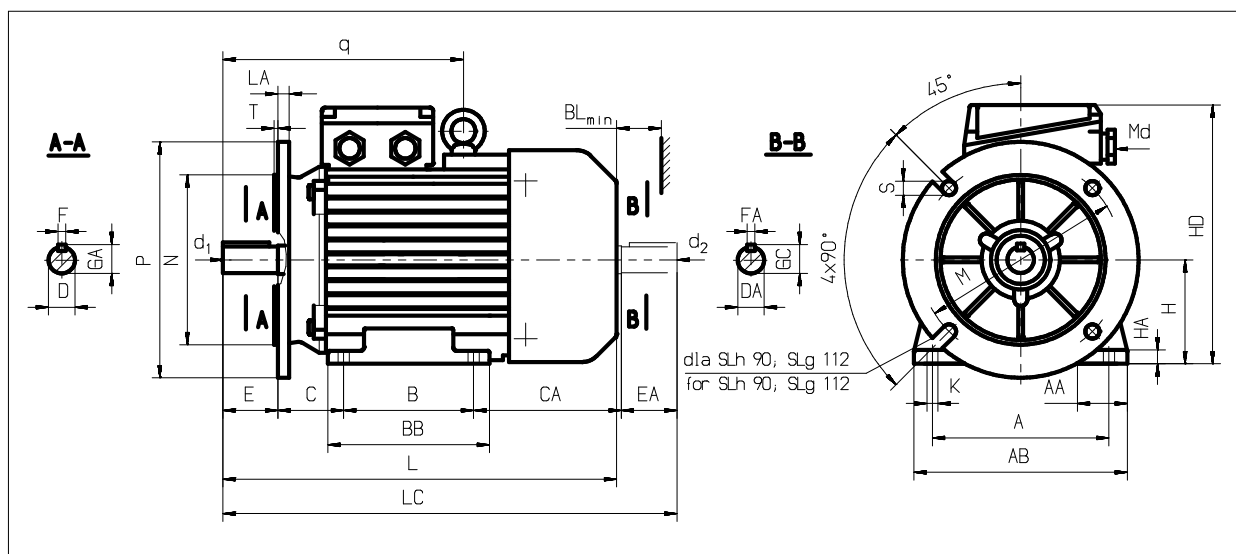

### Wymiary gabarytowe silników kolumnowych na łapach Overall dimensions for foot-flange-mounted motors

Typ Type	AA	AB	BB	BL	CA	d1,d2	HA	HD	L	LA	LC	q	Md	Łożyisko nr Bearing No
	[mm]													
SLh 90S ...	50	170	153	15	104	M8	10	220	305	8	360	-	M 20 x 1,5	6205 2Z
SLh 90L ...	50	170	153	15	104	M8	10	220	330	8	385	-	M 20 x 1,5	6205 2Z
SLg 100L ...	45	200	172	20	116	M10	14	240	376	11	441	-	M 20 x 1,5	6206 2Z
SLg 112M ...	54	230	174	20	119	M10	14	276	384	12	449	257	M 25 x 1,5	6306 2Z
SLg 112M-8/4WB	54	230	174	20	146	M10	14	276	411	12	476	257	M 25 x 1,5	6306 2Z
SLg 132S ...	56	278	182	40	160	M12	16	310	463	12	549	284	M 25 x 1,5	6308 2Z
SLg 132M ...	56	278	220	40	160	M12	16	310	501	12	587	284	M 25 x 1,5	6308 2Z
SLg 160M ...	60	305	256	40	200	M16	20	370	612	13	738	350	M 40 x 1,5	6309 2Z
SLg 160L ...	60	305	300	40	200	M16	20	370	656	13	782	350	M 40 x 1,5	6309 2Z
SLg 180M ...	70	350	320	40	243	M16	26	408	705	13	825	358	M 40 x 1,5	6311 2Z
SLg 180L ...	70	350	320	40	205	M16	26	408	705	13	825	358	M 40 x 1,5	6311 2Z

Wymiar AB dla silników wielkości 132 z łapami odlewanymi wraz z korpusem wynosi 260 mm.

As to motors of size „132” the dimension AB amounts to 260 mm in case the feet are together with frame casted.

#### Formy wykonania:

- IM 2001, IM 2011, IM 2031 - wg IEC 34-7, PN-EN 60034-7
- IM B35, IM V15, IM V36 - wg IEC 34-7, PN-EN 60034-7

#### Mounting forms:

- IM 2001, IM 2011, IM 2031 - per IEC 34-7, PN-EN 60034-7
- IM B35, IM V15, IM V36 - per IEC 34-7, PN-EN 60034-7