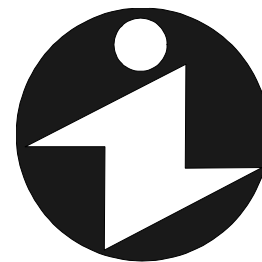

**FABRYKA MASZYN ELEKTRYCZNYCH S.A.****indukta**

# KARTA KATALOGOWA

# CATALOGUE CARD

Trójfazowe silniki indukcyjne  
przeciwwybuchowe nieiskrzące  
z ochroną typu „n”

 II 3G Ex nA II T3 – T4

Three-phase induction explosion-proof non-  
sparking with type of protection „n” motors

 II 3G Ex nA II T3 – T4

**Cantoni**®  
**GROUP**

TELEFON: [48] [33] 827-20-00 ÷ 04

FAX: [48] [33] 827-20-97 ÷ 99

e-mail: [indukta@cantonigroup.com](mailto:indukta@cantonigroup.com)

<http://www.indukta.com.pl>

## Zastosowanie

- Trójfazowe silniki indukcyjne, klatkowe, jednobiegowe, budowy przeciwybuchowej **Grupy II Kategorii 3G** z ochroną typu 'n' Ex "nA" są przeznaczone do pracy w przestrzeniach zagrożonych wybuchem mieszanin gazów lub par z powietrzem innych niż zakłady górnicze. Urządzenia z zabezpieczeniem typu „n” to urządzenia elektryczne, niezdolne ze względów konstrukcyjnych i zasady działania do zapalenia mieszaniny wybuchowej w normalnych warunkach pracy. Litera „A” w oznaczeniu „nA” oznacza urządzenia nieiskrzące. Silniki spełniają klasę temperaturową T3 tzn. maksymalna temperatura dowolnej części silnika nie przekracza +200°C lub klasę temperaturową T4 tzn. maksymalna temperatura dowolnej części silnika nie przekracza +135°C.

Silniki są zgodne z normami PN-EN 60079-0, PN-EN 60079-15 i dyrektywą europejską ATEX 94/9/EC.

Silniki przeznaczone są do pracy w **Strefie 2**. **Strefa 2** obejmuje obszary, w których wystąpienie atmosfery wybuchowej nie jest prawdopodobne, ale jeśli występuje to bardzo rzadko i tylko na krótki okres.

### Charakterystyka wykonania:

- moce znamionowe podane są dla pracy S1,
- napięcie znamionowe 230, 400, 500 [V],
- częstotliwość napięcia zasilania 50 [Hz],
- temperatura otoczenia od -20 do +40[°C],
- wysokość instalowania do 1000 [m] n.p.m.,
- izolacja klasy F,
- stopień ochrony IP 55,
- z jednym czopem końcowym wału wg rysunku wymiarowego (dwa końce wału na życzenie),
- skrzynka zaciskowa z dławnicami i tabliczką 6-zaciskową,
- w wielkościach mechanicznych od 90 do 112 istnieje możliwość wykonania silników ze skrzynką zaciskową z lewej lub prawej strony.

Fabryka wykonuje również silniki różniące się od wykonania podstawowego po uzgodnieniu szczegółów konstrukcyjnych i terminów dostaw.

### Sposób zamawiania:

- W zamówieniu należy podać pełne określenie typu silnika, moc, napięcie zasilające, prędkość obrotową, klasę temperaturową, formę wykonania oraz inne szczegóły niekatalogowego lub specjalnego wykonania.

- Przykład:

Typ:  $\text{Ex}$  II 3G Ex nA II T3 Sg 112M-2  
 Moc: 4 kW  
 Napięcie: 400V  
 Prędkość obrotowa: 2875 min<sup>-1</sup>  
 Klasa temperaturowa: T3  
 Forma wykonania: IM 1001

## Applications

- The three-phase induction squirrel-cage, one speed, explosion proof, **Group II Category 3G** motors Ex "nA" with type of protection "n" are adapted for operating in areas endangered by explosion, other than mining, due to the presence of mixture of gases or vapours with an air. Devices with type of protection "n" are not capable to ignition of explosive mixture in normal operation. Letter "A" in "nA" means non-sparking device.

The motors are designed for temperature class T3 which means that the maximal temperature of any part of the motor can not exceed +200°C or for temperature class T4 where maximal temperature can not exceed +135°C.

The motors meet requirements of standards EN 60079-0, EN 60079-15 and are in accordance with ATEX Directive 94/9/EC.

The motors are intended to work in **Zone 2**. **Zone 2** covers areas in which occurrence of an explosive atmosphere is not likely, but if one should occur, then only rarely and only for a short period.

### Features:

- rated outputs for continuous duty,
- rated voltage 230, 400, 500 [V],
- frequency 50 [Hz],
- environment temperature -20 to +40[°C],
- altitude up to 1000 [m] above sea level,
- insulation class F,
- protection degree IP 55,
- one free shaft extension according to dimension drawing (two shaft extension on request),
- terminal box with glands and terminal board with 6 terminals,
- there is a possibility to offer the motors of mechanical size 90 and 112 with terminal box mounted in the left or right side of the motor's frame

Factory produces various types of motors but constructional details and delivery time are to be individual agreed

### How to order:

- In the order there must be clearly given: full designation of the motor, rated output, rated voltage, rated speed, temperature class, mounting form and all other details for non catalogue execution.
- Example:

Type:  $\text{Ex}$  II 3G Ex II T3 Sg 112M-2  
 Rated output: 4 kW  
 Voltage: 400V  
 Rpm: 2875  
 Temperature class: T3  
 Mounting form: IM 1001

## PARAMETRY EKSPLOATACYJNE SILNIKÓW II 3G Ex nA II T3

### PERFORMANCES OF MOTORS II 3G Ex nA II T3

Typ silnika	$P_n$		$n_n$	$\eta_n$	$\cos \phi_n$	$I_{1n}$ przy nap. znam. 230V	$I_{1n}$ przy nap. znam. 400V	$I_{1n}$ przy nap. znam. 500V	$\frac{M_1}{M_n}$	$\frac{I_1}{I_n}$	$\frac{M_{max}}{M_n}$	J	Masa IM B3
	Rated output		Rated speed	Efficiency	Power factor	Full-load amps at 230V	Full-load amps at 400V	Full-load amps at 500V	Locked rotor torque	Locked rotor current	Break-down torque	Moment of inertia	Weight IM B3
Type of motor	[kW]	[HP]	[min <sup>-1</sup> ]	[%]	-	[A]	[A]	[A]	[-]	[-]	[-]	[kgm <sup>2</sup> ]	[kg]
<b>2p=2                      n<sub>s</sub>=3000 obr/min                      no-load rpm=3000</b>													
Sh 90S-2-T3	1,5	2,0	2850	77,8	0,81	6,1	3,5	2,8	2,9	6,0	3,0	0,0013	12,5
Sh 90L-2-T3	2,2	3,0	2860	81,7	0,82	8,2	4,7	3,8	3,0	7,1	3,2	0,0020	15,9
Sg 100L-2-T3	2,4	3,3	2905	81,7	0,88	8,3	4,8	3,8	2,7	8,3	3,0	0,0048	22,8
Sg 112M-2-T3	4,0	5,5	2875	85,5	0,91	13,0	7,5	6,0	2,0	6,5	2,4	0,0080	33,0
Sg 132S-2A-T3	5,5	7,5	2915	85,3	0,90	18,1	10,4	8,3	2,4	7,1	2,8	0,0150	57,0
Sg 132S-2B-T3	7,0	9,4	2920	87,3	0,91	22,1	12,7	10,2	2,5	7,7	3,1	0,0190	76,0
Sg 160M-2A-T3	11,0	15,0	2920	88,1	0,89	35,0	20,1	16,1	2,3	6,5	2,8	0,0390	101,0
Sg 160L-2-T3	16,0	21,4	2940	90,8	0,90	49,2	28,3	22,6	2,8	7,7	3,5	0,0580	132,0
Sg 180M-2-T3	18,5	25,0	2945	91,6	0,92	55,3	31,8	25,4	2,3	8,25	3,4	0,0850	188,0
<b>2p=4                      n<sub>s</sub>=1500 obr/min                      no-load rpm=1500</b>													
Sh 90S-4-T3	1,1	1,5	1405	72,9	0,80	4,7	2,7	2,2	2,0	4,65	2,4	0,0027	12,7
Sh 90L-4-T3	1,5	2,0	1415	75,5	0,77	6,4	3,7	3,0	2,5	5,3	2,7	0,0028	15,5
Sg 100L-4A-T3	2,2	3,0	1425	77,1	0,80	9,0	5,2	4,2	2,4	5,9	2,8	0,0070	21,9
Sg 100L-4B-T3	3,0	4,0	1415	78,0	0,81	12,0	6,9	5,5	2,6	5,75	2,9	0,0082	24,0
Sg 112M-4-T3	4,0	5,5	1430	82,6	0,85	14,4	8,3	6,6	2,5	6,9	3,0	0,0140	33,0
Sg 132S-4-T3	5,5	7,5	1455	84,5	0,84	19,3	11,1	8,9	2,2	6,8	2,8	0,0280	60,0
Sg 132M-4-T3	7,5	10,0	1450	85,9	0,86	25,4	14,6	11,7	2,3	7,0	2,8	0,0350	71,0
Sg 160M-4-T3	11,0	15,0	1460	88,5	0,85	36,7	21,1	16,9	2,2	7,2	3,1	0,0610	104,0
Sg 160L-4-T3	15,0	20,0	1460	89,7	0,86	48,7	28,0	22,4	2,3	7,4	3,0	0,0790	126,0
Sg 180M-4-T3	18,5	25,0	1470	91,4	0,89	57,4	33,0	26,4	2,8	7,9	2,7	0,1550	173,0
Sg 180L-4-T3	22,0	30,0	1465	91,7	0,90	66,6	38,3	30,6	2,8	7,7	2,6	0,1850	200,0
<b>2p=2                      n<sub>s</sub>=1000 obr/min                      no-load rpm=1000</b>													
Sh 90S-6-T3	0,75	1,0	915	69,8	0,73	3,7	2,1	1,7	1,9	3,7	2,1	0,0020	12,1
Sh 90L-6-T3	1,10	1,5	920	73,3	0,71	5,2	3,0	2,4	2,2	4,05	2,5	0,0028	15,5
Sg 100L-6-T3	1,50	2,0	945	72,5	0,73	7,1	4,1	3,3	2,1	4,5	2,4	0,0090	21,0
Sg 112M-6-T3	2,20	3,0	960	81,2	0,77	8,9	5,1	4,1	2,3	5,9	2,7	0,0190	32,0
Sg 132S-6-T3	3,00	4,0	945	79,7	0,80	11,8	6,8	5,4	2,1	5,3	2,8	0,0240	52,0
Sg 132M-6A-T3	4,00	5,5	950	82,9	0,82	14,8	8,5	6,8	2,3	6,1	2,9	0,0320	64,0
Sg 132M-6B-T3	5,50	7,5	950	83,3	0,82	20,2	11,6	9,3	2,7	6,4	3,4	0,0390	71,0
Sg 160M-6-T3	7,50	10,0	960	86,3	0,80	27,3	15,7	12,6	2,2	6,5	2,8	0,0680	99,0
Sg 160L-6-T3	11,00	15,0	960	87,5	0,82	38,3	22,0	17,6	2,3	6,8	3,3	0,0980	126,0
Sg 180L-6-T3	13,5	18,1	980	89,3	0,82	46,3	26,6	21,3	3,2	6,7	2,4	0,2210	169,0

## PARAMETRY EKSPLOATACYJNE SILNIKÓW II 3G Ex nA II T4 PERFORMANCES OF MOTORS II 3G Ex nA II T4

Typ silnika Type of motor	$P_n$		$n_n$	$\eta_n$	$\cos \varphi_n$	$I_{1n}$ przy nap. znam. 230V	$I_{1n}$ przy nap. znam. 400V	$I_{1n}$ przy nap. znam. 500V	$\frac{M_1}{M_n}$	$\frac{I_1}{I_n}$	$\frac{M_{max}}{M_n}$	J	Masa IM B3
	[kW]	[HP]	[min <sup>-1</sup> ]	[%]	-	[A]	[A]	[A]	Locked rotor torque	Locked rotor current	Break- down torque	Moment of inertia	Weight IM B3
		$2p=2$			$n_s=3000$ obr/min			no-load rpm=3000					
Sh 90S-2-T4	1,0	1,36	2895	79,6	0,78	4,0	2,3	1,8	3,8	7,5	4,1	0,0013	12,7
Sh 90L-2-T4	1,2	1,60	2855	79,5	0,90	4,2	2,4	1,9	3,2	7,4	3,2	0,0020	16,5
Sg 100L-2-T4	1,5	2,00	2900	79,2	0,91	5,2	3,0	2,4	2,8	7,8	3,1	0,0048	22,5
Sg 112M-2-T4	2,0	2,70	2915	85,8	0,91	6,4	3,7	3,0	3,0	7,95	3,5	0,0080	33,0
Sg 132S-2A-T4	2,5	3,40	2930	85,2	0,91	8,0	4,6	3,7	2,4	7,5	3,2	0,0150	58,0
Sg 132S-2B-T4	3,5	4,80	2935	86,1	0,92	11,1	6,4	5,1	2,8	8,0	3,4	0,0180	72,0
Sg 160M-2A-T4	5,0	6,80	2945	87,7	0,90	16,0	9,2	7,4	3,0	7,65	3,6	0,0390	101,0
Sg 160M-2B-T4	6,0	8,10	2950	88,7	0,91	18,6	10,7	8,6	2,9	7,65	3,3	0,0470	112,0
Sg 160L-2-T4	7,5	10,00	2950	90,0	0,92	22,8	13,1	10,5	3,2	7,75	3,5	0,0580	129,0
Sg 180M-2-T4	10,0	13,6	2950	90,4	0,92	30,3	17,4	13,9	2,4	8,5	3,6	0,085	191,0
		$2p=4$			$n_s=1500$ obr/min			no-load rpm=1500					
Sh 90S-4-T4	0,8	1,07	1435	75,8	0,75	3,5	2,0	1,6	2,6	5,7	3,1	0,0027	12,7
Sh 90L-4-T4	1,1	1,50	1430	76,0	0,78	4,7	2,7	2,2	2,8	6,2	3,0	0,0028	16,0
Sg 100L-4A-T4	1,5	2,00	1430	78,1	0,83	5,7	3,3	2,6	2,6	6,2	3,1	0,0070	22,1
Sg 100L-4B-T4	2,0	2,70	1425	79,8	0,85	7,5	4,3	3,4	2,4	6,2	2,7	0,0082	23,9
Sg 112M-4-T4	2,4	3,30	1450	83,8	0,84	8,5	4,9	3,9	3,0	7,9	3,7	0,0140	33,0
Sg 132S-4-T4	3,0	4,00	1465	85,5	0,85	10,4	6,0	4,8	2,3	7,7	3,0	0,0280	60,0
Sg 132M-4-T4	4,0	5,50	1460	86,2	0,87	13,4	7,7	6,2	2,2	7,4	3,0	0,0350	71,0
Sg 160M-4-T4	6,0	8,10	1465	88,6	0,87	19,7	11,3	9,0	2,0	7,25	2,8	0,0610	105,0
Sg 160L-4-T4	7,5	10,00	1465	89,4	0,88	24,0	13,8	11,0	2,2	7,6	2,9	0,0790	127,0
Sg 180L-4-T4	11,0	15,0	1465	89,8	0,92	33,6	19,3	15,4	2,0	5,8	2,3	0,1850	199,0
		$2p=6$			$n_s=1000$ obr/min			no-load rpm=1000					
Sh 90S-6-T4	0,65	0,88	935	71,1	0,68	3,5	2,0	1,6	2,3	4,1	2,6	0,0020	12,4
Sh 90L-6-T4	0,80	1,07	950	73,9	0,61	4,5	2,6	2,1	3,1	4,75	3,3	0,0028	15,5
Sg 100L-6-T4	1,20	1,60	950	73,7	0,74	5,6	3,2	2,6	2,3	4,8	2,7	0,0090	22,1
Sg 112M-6-T4	1,60	2,10	970	81,1	0,73	6,8	3,9	3,1	2,8	6,7	3,4	0,0190	32,0
Sg 132S-6-T4	2,20	3,00	960	80,7	0,78	8,9	5,1	4,1	2,3	5,9	3,0	0,0240	52,0
Sg 132M-6A-T4	2,80	3,80	960	84,3	0,80	10,4	6,0	4,8	2,4	6,5	2,9	0,0320	63,0
Sg 132M-6B-T4	4,00	5,50	960	84,8	0,83	14,3	8,2	6,6	2,5	7,0	3,5	0,0390	71,0
Sg 160M-6-T4	5,50	7,50	965	87,2	0,81	19,5	11,2	9,0	2,2	6,65	2,9	0,0680	101,0
Sg 160L-6-T4	7,00	9,40	970	88,6	0,84	23,7	13,6	10,9	2,4	7,5	3,1	0,0980	125,0

### Wymiary montażowe silników na łapach Mounting dimensions for foot-mounted motors

Typ Type	A	B	C	D,DA	E,EA	F,FA	GA,GC	H	K
	[mm]								
Sh 90S ...	140	100	56	24j6	50	8h9	27,0	90	10
Sh 90L ...	140	125	56	24j6	50	8h9	27,0	90	10
Sg 100L ...	160	140	63	28j6	60	8h9	31,0	100	12
Sg 112M ...	190	140	70	28j6	60	8h9	31,0	112	12
Sg 132S ...	216	140	89	38k6	80	10h9	41,0	132	12
Sg 132S-2B	216	140	89	38k6	80	10h9	41,0	132	12
Sg 132M ...	216	178	89	38k6	80	10h9	41,0	132	12
Sg 160M ...	254	210	108	42k6	110	12h9	45,0	160	15
Sg 160L ...	254	254	108	42k6	110	12h9	45,0	160	15
Sg 180M ...	279	241	121	48k6	110	14h9	51,5	180	15
Sg 180L ...	279	279	121	48k6	110	14h9	51,5	180	15

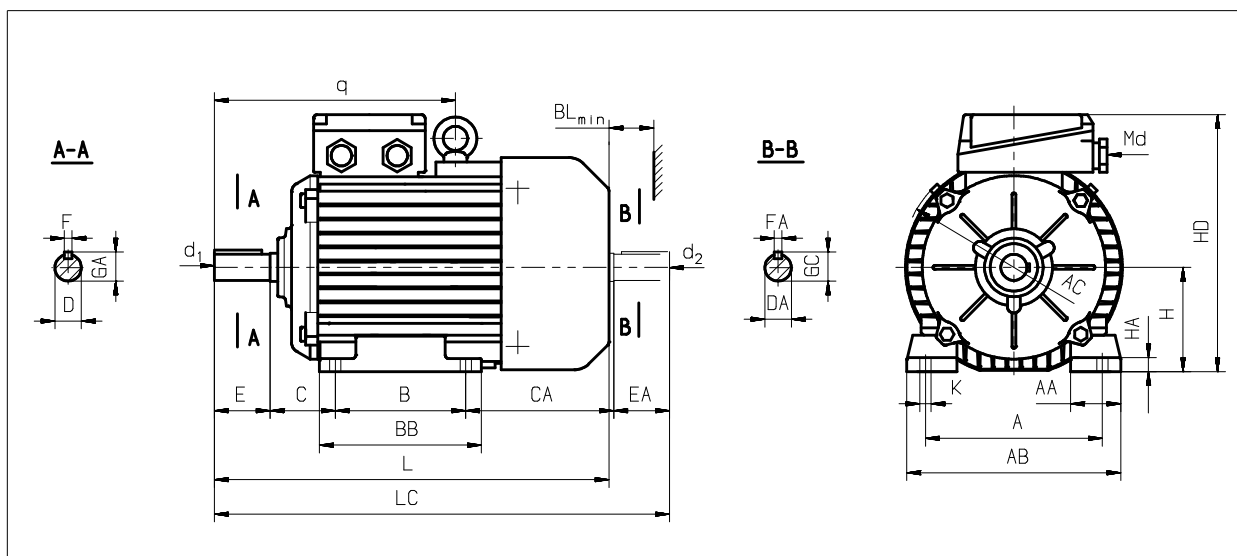

### Wymiary gabarytowe silników na łapach Overall dimensions for foot-mounted motors

Typ Type	AA	AB	AC	BB	BL	CA	d1,d2	HA	HD	L	LC	q	Md	Łożysko nr Bearing No
	[mm]													
Sh 90S ...	50	170	185	153	15	104	M8	10	220	305	360	-	M 20 x 1,5	6205 2Z
Sh 90L ...	50	170	185	153	15	104	M8	10	220	330	385	-	M 20 x 1,5	6205 2Z
Sg 100L ...	45	200	206	172	20	116	M10	14	240	376	441	-	M 20 x 1,5	6206 2Z
Sg 112M ...	54	230	245	174	20	119	M10	14	276	384	449	257	M 25 x 1,5	6306 2Z
Sg 132S ...	56	278	274	182	40	160	M12	16	310	463	549	284	M 25 x 1,5	6308 2Z
Sg 132S-2B	56	278	274	220	40	198	M12	16	310	501	587	284	M 25 x 1,5	6308 2Z
Sg 132M ...	56	278	274	220	40	160	M12	16	310	501	587	284	M 25 x 1,5	6308 2Z
Sg 160M ...	60	305	323	256	40	200	M16	20	370	612	738	350	M 40 x 1,5	6309 2Z
Sg 160L ...	60	305	323	300	40	200	M16	20	370	656	782	350	M 40 x 1,5	6309 2Z
Sg 180M-4...	70	350	360	320	40	243	M16	26	408	705	825	358	M 40 x 1,5	6311 2Z
Sg 180L-6...	70	350	360	320	40	243	M16	26	408	705	825	358	M 40 x 1,5	6311 2Z
Sg 180M-2...	70	350	360	320	40	256	M16	26	408	756	876	358	M 40 x 1,5	6311 2Z
Sg 180L-4...	70	350	360	320	40	256	M16	26	408	756	876	358	M 40 x 1,5	6311 2Z

Wymiar AB dla silników wielkości 132 z łapami odlewanymi wraz z korpusem wynosi 260 mm.

As to motors of size „132” the dimension AB amounts to 260 mm in case the feet are together with frame casted.

#### Formy wykonania:

- IM 1001, IM 1011, IM 1031, IM 1051, IM 1061, IM 1071 - wg IEC 34-7, PN-EN 60034-7 (IM 1011 – z daszkiem ochronnym)
- IM B3, IM V5, IM V6, IM B6, IM B7, IM B8 - wg IEC 34-7, PN-EN 60034-7 (IM V5 – z daszkiem ochronnym)

#### Mounting forms:

- IM 1001, IM 1011, IM 1031, IM 1051, IM 1061, IM 1071 - per IEC 34-7, EN 60034-7 (IM 1011 – with protective cap)
- IM B3, IM V5, IM V6, IM B6, IM B7, IM B8 - per IEC 34-7, EN 60034-7 (IM V5 – with protective cap)

### Wymiary montażowe silników kołnierzych Mounting dimensions for flange-mounted motors

Typ Type	D,DA	E,EA	F,FA	GA,GC	M	N	P	S	T
	[mm]								
SKh 90S ...	24j6	50	8h9	27,0	165	130j6	200	12	3,5
SKh 90L ...	24j6	50	8h9	27,0	165	130j6	200	12	3,5
SKg 100L ...	28j6	60	8h9	31,0	215	180j6	250	15	4,0
SKg 112M ...	28j6	60	8h9	31,0	215	180j6	250	15	4,0
SKg 132S ...	38k6	80	10h9	41,0	265	230j6	300	15	4,0
SKg 132S-2B	38k6	80	10h9	41,0	265	230j6	300	15	4,0
SKg 132M ...	38k6	80	10h9	41,0	265	230j6	300	15	4,0
SKg 160M ...	42k6	110	12h9	45,0	300	250j6	350	19	5,0
SKg 160L ...	42k6	110	12h9	45,0	300	250j6	350	19	5,0
SKg 180M ...	48k6	110	14h9	51,5	300	250j6	350	19	5,0
SKg 180L ...	48k6	110	14h9	51,5	300	250j6	350	19	5,0

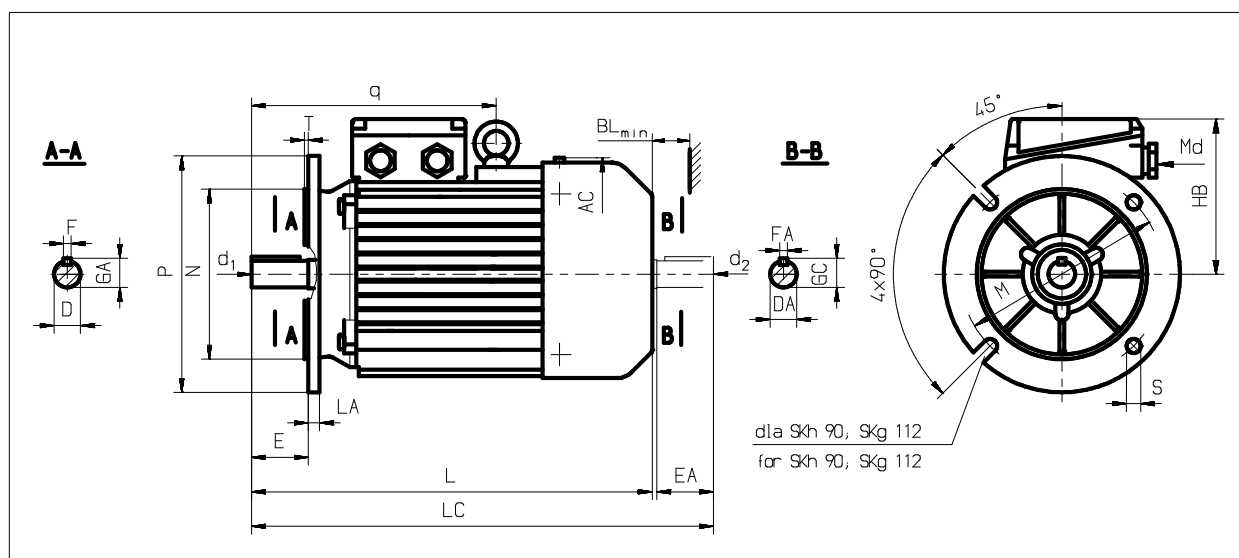

### Wymiary gabarytowe silników kołnierzych Overall dimensions for flange-mounted motors

Typ Type	AC	BL	d1,d2	HB	L	LA	LC	q	Md	Łożysko nr Bearing No
	[mm]									
SKh 90S ...	185	15	M8	130	305	8	360	-	M 20 x 1,5	6205 2Z
SKh 90L ...	185	15	M8	130	330	8	385	-	M 20 x 1,5	6205 2Z
SKg 100L ...	206	20	M10	140	376	11	441	-	M 20 x 1,5	6206 2Z
SKg 112M ...	245	20	M10	164	384	12	449	257	M 25 x 1,5	6306 2Z
SKg 132S ...	274	40	M12	178	463	12	549	284	M 25 x 1,5	6308 2Z
SKg 132S-2B	274	40	M12	178	501	12	587	284	M 25 x 1,5	6308 2Z
SKg 132M ...	274	40	M12	178	501	12	587	284	M 25 x 1,5	6308 2Z
SKg 160M ...	323	40	M16	210	612	13	738	350	M 40 x 1,5	6309 2Z
SKg 160L ...	323	40	M16	210	656	13	782	350	M 40 x 1,5	6309 2Z
SKg 180M-4...	360	40	M16	228	705	13	825	358	M 40 x 1,5	6311 2Z
SKg 180L-6...										
SKg 180M-2...	360	40	M16	228	756	13	876	358	M 40 x 1,5	6311 2Z
SKg 180L-4...										

#### Formy wykonania:

- IM 3001, IM 3011, IM 3031 - wg IEC 34-7, PN-EN 60034-7 (IM 3011 – z daszkiem ochronnym)
- IM B5, IM V1, IM V3 - wg IEC 34-7, PN-EN 60034-7 (IM V1 – z daszkiem ochronnym)

#### Mounting forms:

- IM 3001, IM 3011, IM 3031 - per IEC 34-7, EN 60034-7 (IM 3011 – with protective cap)
- IM B5, IM V1, IM V3 - per IEC 34-7, EN 60034-7 (IM V1 – with protective cap)

### Wymiary montażowe silników kołnierzowych na łapach Mounting dimensions for foot-flange-mounted motors

Typ Type	A	B	C	D,DA	E,EA	F,FA	GA,GC	H	K	M	N	P	S	T
	[mm]													
SLh 90S ...	140	100	56	24j6	50	8h9	27,0	90	10	165	130j6	200	12	3,5
SLh 90L ...	140	125	56	24j6	50	8h9	27,0	90	10	165	130j6	200	12	3,5
SLg 100L ...	160	140	63	28j6	60	8h9	31,0	100	12	215	180j6	250	15	4,0
SLg 112M ...	190	140	70	28j6	60	8h9	31,0	112	12	215	180j6	250	15	4,0
SLg 132S ...	216	140	89	38k6	80	10h9	41,0	132	12	265	230j6	300	15	4,0
SLg 132S-2B	216	140	89	38k6	80	10h9	41,0	132	12	265	230j6	300	15	4,0
SLg 132M ...	216	178	89	38k6	80	10h9	41,0	132	12	265	230j6	300	15	4,0
SLg 160M ...	254	210	108	42k6	110	12h9	45,0	160	15	300	250j6	350	19	5,0
SLg 160L ...	254	254	108	42k6	110	12h9	45,0	160	15	300	250j6	350	19	5,0
SLg 180M ...	279	241	121	48k6	110	14h9	51,5	180	15	300	250j6	350	19	5,0
SLg 180L ...	279	279	121	48k6	110	14h9	51,5	180	15	300	250j6	350	19	5,0

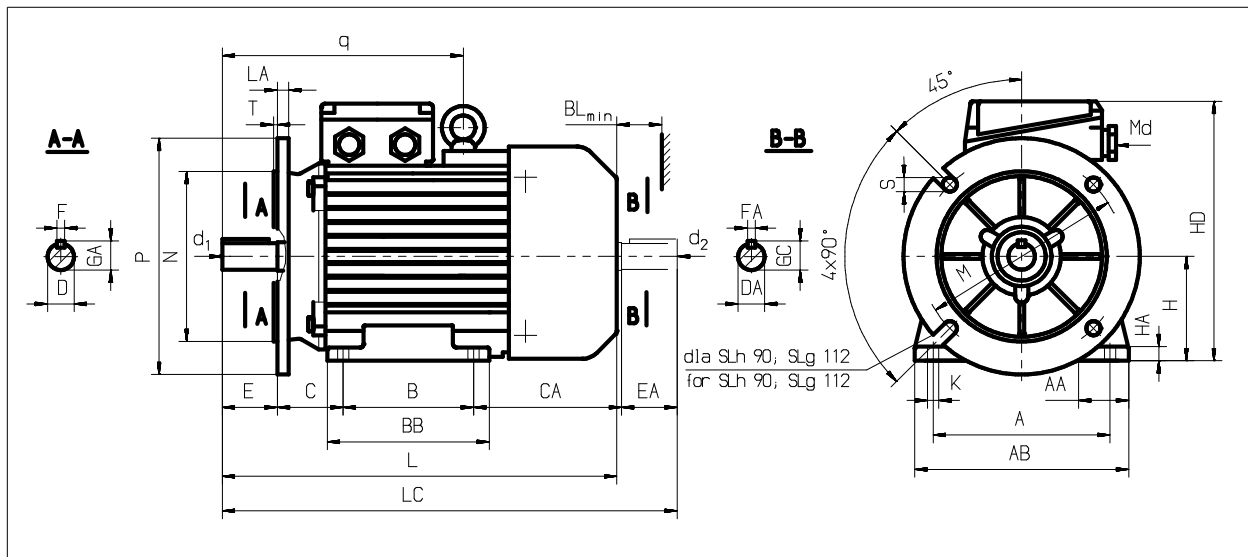

### Wymiary gabarytowe silników kołnierzowych na łapach Overall dimensions for foot-flange-mounted motors

Typ Type	AA	AB	BB	BL	CA	d1,d2	HA	HD	L	LA	LC	q	Md	Łożysko nr Bearing No
	[mm]													
SLh 90S ...	50	170	153	15	104	M8	10	220	305	8	360	-	M 20 x 1,5	6205 2Z
SLh 90L ...	50	170	153	15	104	M8	10	220	330	8	385	-	M 20 x 1,5	6205 2Z
SLg 100L ...	45	200	172	20	116	M10	14	240	376	11	441	-	M 20 x 1,5	6206 2Z
SLg 112M ...	54	230	174	20	119	M10	14	276	384	12	449	257	M 25 x 1,5	6306 2Z
SLg 132S ...	56	278	182	40	160	M12	16	310	463	12	549	284	M 25 x 1,5	6308 2Z
SLg 132S-2B	56	278	220	40	198	M12	16	310	501	12	587	284	M 25 x 1,5	6308 2Z
SLg 132M ...	56	278	220	40	160	M12	16	310	501	12	587	284	M 25 x 1,5	6308 2Z
SLg 160M ...	60	305	256	40	200	M16	20	370	612	13	738	350	M 40 x 1,5	6309 2Z
SLg 160L ...	60	305	300	40	200	M16	20	370	656	13	782	350	M 40 x 1,5	6309 2Z
SLg 180M-4...	70	350	320	40	243	M16	26	408	705	13	825	358	M 40 x 1,5	6311 2Z
SLg 180L-6...														
SLg 180M-2...	70	350	320	40	256	M16	26	408	756	13	876	358	M 40 x 1,5	6311 2Z
SLg 180L-4...														

Wymiar AB dla silników wielkości 132 z łapami odlewany wraz z korpusem wynosi 260 mm.

As to motors of size „132” the dimension AB amounts to 260 mm in case the feet are together with frame casted.

#### Formy wykonania:

- IM 2001, IM 2011, IM 2031 - wg IEC 34-7, PN-EN 60034-7 (IM 2011 – z daszkiem ochronnym)
- IM B35, IM V15, IM V36 - wg IEC 34-7, PN-EN 60034-7 (IM V15 – z daszkiem ochronnym)

#### Mounting forms:

- IM 2001, IM 2011, IM 2031 - per IEC 34-7, EN 60034-7 (IM 2011 – with protective cap)
- IM B35, IM V15, IM V36 - per IEC 34-7, EN 60034-7 (IM V15 – with protective cap)

### Wymiary montażowe silników z tarczą kołnierkową B14 Mounting dimensions for motors with flange B14

Typ Type	D,DA	E,EA	F,FA	GA,GC	B14						
					Kołnierz Flange	M	N	P	S	LA	T
SKh 90 ...	24j6	50	8h9	27,0	FT130/C160	130	110j6	160	M8	10	3,5
					FT115/C140	115	95j6	140	M8	10	3,0
SKg 100 ...	28j6	60	8h9	31,0	FT165/C200	165	130j6	200	M10	12	3,5
					FT130/C160	130	110j6	160	M8	12	3,5
SKg 112 ...	28j6	60	8h9	31,0	FT165/C200	165	130j6	200	M10	12	3,5
					FT130/C160	130	110j6	160	M8	12	3,5
SKg 132 ...	38k6	80	10h9	41,0	FT215/C250	215	180j6	250	M12	12	4,0
					FT165/C200	165	130j6	200	M10	12	3,5
SKg 160 ...	42k6	110	12h9	45,0	FT265/C300	265	230j6	300	M12	13	4,0
					FT215/C250	215	180j6	250	M12	20	4,0

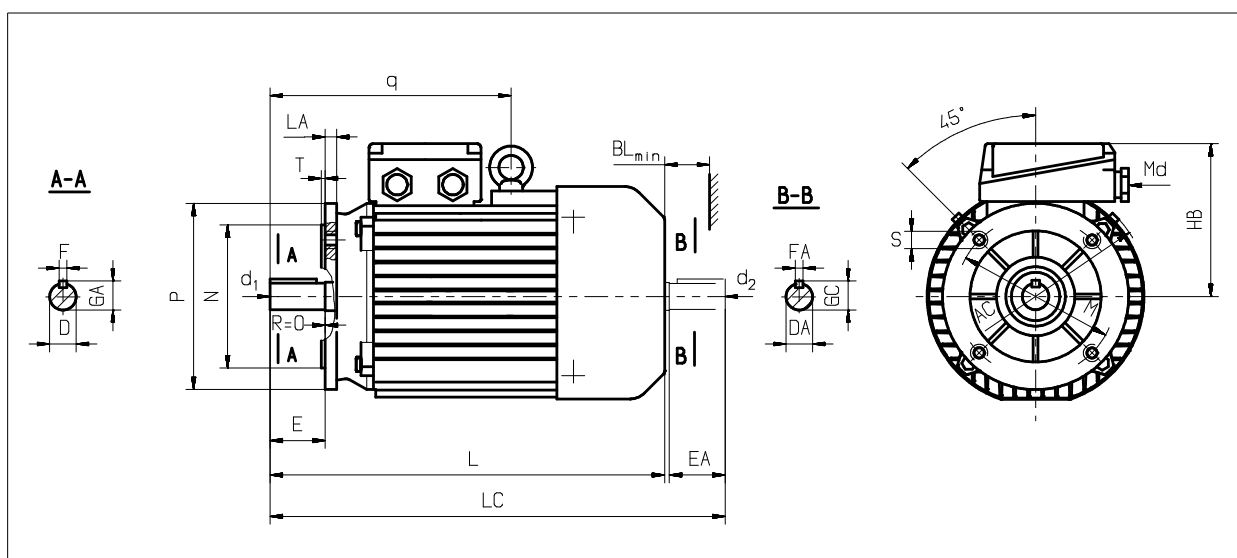

### Wymiary gabarytowe silników z tarczą kołnierkową B14 Overall dimensions for motors with flange B14

Typ Type	AC	BL	d1,d2	HB	L	LC	q	Md	Łożysko nr Bearing No
	[mm]								
SKh 90S ...	185	15	M8	130	305	360	-	M 20 x 1,5	6205 2Z
SKh 90L ...	185	15	M8	130	330	385	-	M 20 x 1,5	6205 2Z
SKg 100L ...	206	20	M10	140	376	441	-	M 20 x 1,5	6206 2Z
SKg 112M ...	245	20	M10	164	384	449	257	M 25 x 1,5	6306 2Z
SKg 132S ...	274	40	M12	178	463	549	284	M 25 x 1,5	6308 2Z
SKg 132S-2B	274	40	M12	178	501	587	284	M 25 x 1,5	6308 2Z
SKg 132M ...	274	40	M12	178	501	587	284	M 25 x 1,5	6308 2Z
SKg 160M ...	323	40	M16	210	612	738	350	M 40 x 1,5	6309 2Z
SKg 160L ...	323	40	M16	210	656	782	350	M 40 x 1,5	6309 2Z

Wymiary silników kołnierkowych na łapach IM B34 (oprócz tarczy kołnierkowej) –  
patrz tabele dla IM B35 na stronie 6

Dimensions for foot-flange motors IM B34 (except flange shield) – see tables for IM B35 on page 6

Wymiar AB dla silników wielkości 132 z łapami odlewanymi wraz z korpusem wynosi 260 mm.

As to motors of size „132” the dimension AB amounts to 260 mm in case the feet are together with frame casted.

Formy wykonania:

- IM 3601, IM 3611, IM 3631 - wg IEC 34-7, PN-EN 60034-7
- IM B14 - wg IEC 34-7, PN-EN 60034-7

Mounting forms:

- IM 3601, IM 3611, IM 3631 - per EN 60034-7
- IM B14 - per IEC 34-7, EN 60034-7